

novis

WasteValorization

Portfolio

- Analyzing waste -



- and turning it into value -

Our mission

Finding innovative solutions to transform waste products into new resources is the core idea behind **Novis**. We believe, if you use modern technology, there is potential in almost every material nowadays. Nobody can afford to throw value away.



Our focus lies on biotechnological processes, but in the past we have also worked with chemical and thermal conversion. What ever works best for the individual product.

In the end our costumers have to be provided with a continuous supply of marketable products, either electricity, new products or raw materials.

*Products **Novis** has solutions for:*



Reach your goals with our services

Consulting and planning

- Anyone with a waste substrate can contact us and our experts check for its potential use.
- If there is a solution to use the product, we examine the preconditions and plan the approach and realisation.



Research and development

- Finding solutions for our costumers means process engineering using the most advance technologies.
- Newly developed processes are tested and optimized in our own laboratory.



Construction and start-up

- Upon assignment, we engineer, build and start-up the custom made, industrial plant turn-key.
- We only work with high-quality manufacturers according to the highest German and European standards and regulations.



Source of income for you

- You receive the opportunity to own a reliable source of income with a high internal interest rate.
- Ideally the income is a combination of avoiding disposal costs and the sales of the new products.



Core technologies

A) Energy generation with biogas

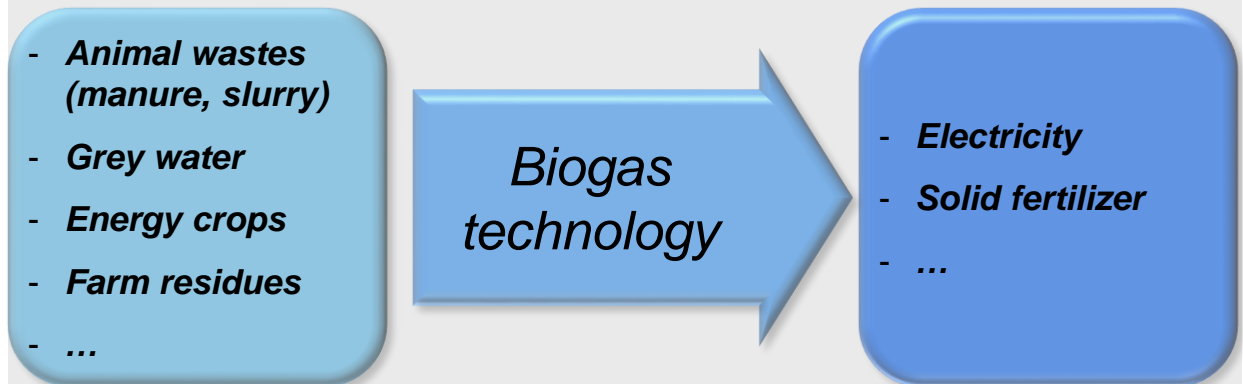

In biogas plants a natural process converts **organic matter*** into renewable energy. Biogas mainly consists of methane gas produced by the digestion of agricultural products, organic waste or manure.

The gas can be used

1. to power generators that produce electricity
2. for thermal applications or steam production
3. upgraded as natural gas and sold to the grid

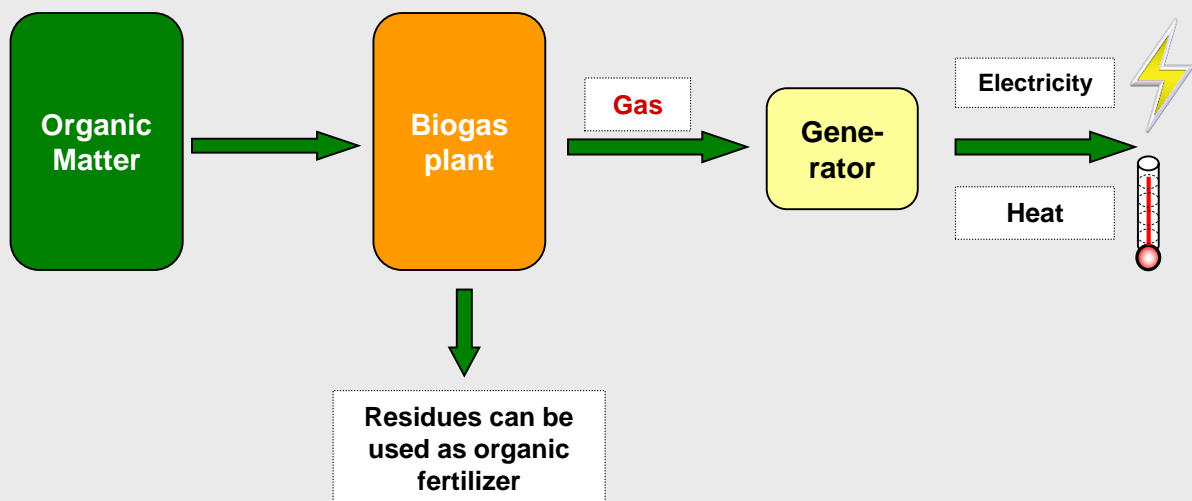

* Due to differences in the composition and digestibility of biomass, the potential of each substrate has to be tested to confirm its suitability for biogas production.

Novis offers biogas plants for

1. HiPo_s

Small-scale applications, e.g. to provide public institutions (schools, hospitals, ...) or small settlements with cooking gas and electricity. Depending on the situation, the electric capacity can be between 10 up to 60 kW_{el}. The plants are simple to use but need a fair amount of manual work. They are specifically designed for developing countries.



Small-scale biogas plant in Mombasa, Kenya



Container biogas plant (to test unconventional feedstock) in San Pedro, Ivory Coast

Novis offers biogas plants for

2. HiPo_M

Medium-scale biogas plants, ranging from 100 to 900 kW_{el}.

This product we sell mainly to agro-industrial businesses, animal and agricultural farmers or to urban waste recovery institutions.

The main focus lies on a reliable, automated production of biogas, which is mainly used to generate electric energy. The produced digestate (residues of the biogas process) is used or sold as a quality organic fertilizer. To increase the efficiency of the plant, it is advisable to utilize the heat created in the CHP-unit.



Medium-scale biogas plant in Zarchlin, Germany



Biogas plant in Aveyron, France



Biogas plant in Ubonthani, Thailand

Novis offers biogas plants for

3. HiPo_{XL}

Large-scale biogas plants, with a capacity of more than 1 MW_{el}.

The product finds applications in the processing industry, large animal and agricultural farming cooperatives or urban waste recovery.

The plants have a modular design to make the sure the installation keeps running in case of service work etc. (redundancy). The fully automated biogas plant guarantees a reliable and efficient process. Biogas can be used directly for thermal processes, can be conditioned to be sold as natural gas or electrified. It is highly recommended to use the produced heat for process heat or cooling. Digestate can be sold or used as a high quality organic fertilizer.



2 MW_{el} biogas plant in Simbach, Germany



*1,6 MW_{el} biogas plant in Velgast,
Germany*



*1 MW_{el} biogas plant in Orth a.d. Donau,
Austria*

Core technologies

B) Biotechnological processes

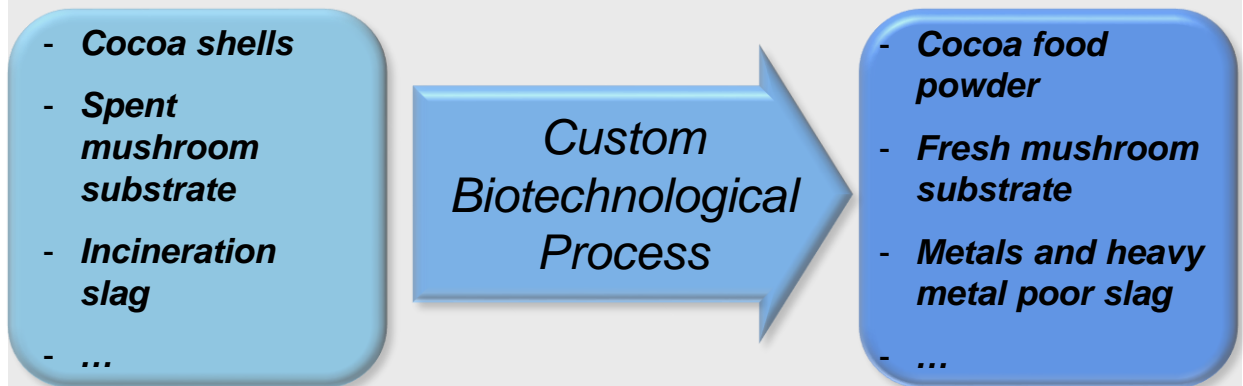

Novis designs unique biotechnological processes to treat materials in order to increase its value. This can also mean to reduce disposal cost as much as possible.

We are generally responsible for the whole development chain from the first analysis of the materials to the design and installation of prototypes all the way to the final full-scale plant.

We conduct research in our company own laboratory. With the generated results we create reliable feasibility studies and find all critical parameters in the process.

Even at this early stage small amounts of the end product are produced and can be tested for its marketability.

Using the results of the lab tests to scale up production and transform it into an industrial plant is the task of our process engineers in the office.

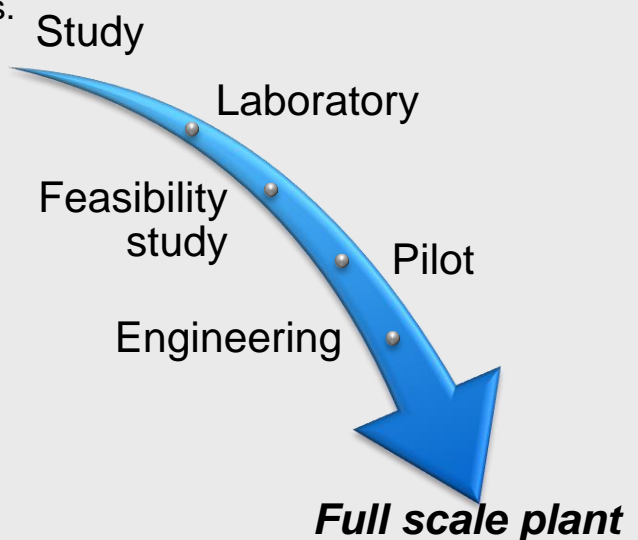

Cocoa shell transformation into food grade cocoa

Novis has developed a process to create cocoa powder from cocoa shells.

Even though the dried and fermented shells are similar in taste and texture to the de-oiled cocoa mass, they can not be used for cocoa mass production due to contaminations and consistency problems.

With a specifically designed process called “cocoa boost” the Novis engineers managed to process the shells and transform them into a food product. A special bacteria mixture was developed to change the cocoa shell properties.



Optimization of cocoa consistency in the laboratory



Construction of the industrial plant

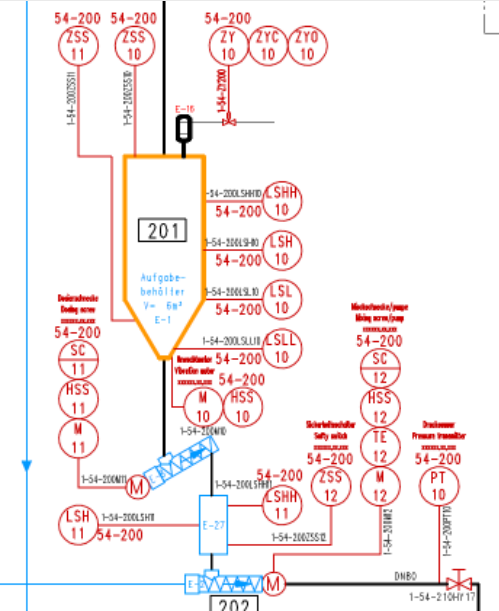

Detailed plan of piping and instrumentation

Bioleaching of incineration slag

On the one hand incineration slag is problematic, because of its high contamination with heavy metals. On the other hand the high metal concentration is a potential source for recycling raw metals like copper, gold, aluminum,...

Novis brings these aspects together and is currently working on a process called “bioleaching”. Metals are extracted from the slag with waste acid from the flue gas treatment. Special bacteria absorb the metals and increase the efficiency of the recovery.

Afterwards the slag can be used as a construction material, recovered metals can be sold and the flue gas effluent is disposed. A triple win for our customer!



Taking slag samples



1st lab scale process tests



Upscaled laboratory tests

Champost recycling

The champignon industry is producing a large portion of champost, or spend champignon substrate, as a waste product. It contains the mushrooms leftovers and a lot of unused fibers. At the moment most of it is spread on agricultural fields at a cost for transport and disposal.

Novis used a selective digestion technology to remove mycelium, sterilize the substrate and recover fibers.



Used substrate after champignon harvest



Recycled fibers



Lab-scale batch digesters and de-watering station

The fibers can be reused in fiber production, which saves cost for otherwise needed peat and saves disposal costs.

Core technologies

C) Incineration/Pyrolysis

- **Nut shells**
- **Problematic waste**
- **Municipal waste**
- ...

**Incineration/
Pyrolysis**

- **Electricity**
- **Fertilizer carbon**
- **Slag**
- ...

As a solution for dry materials with a high caloric value, **Novis** offers thermal utilization technologies.

Depending on the size and input **Novis** builds small scale pyrolysis plants for rural electrification and waste incineration plants.

Pyrolysis

In a pyrolysis plant the material is not completely burned, but heated indirectly. This way a gas is produced, which can be used in a gas engine to produce electricity. No steam cycle, heat exchangers, turbines etc. are needed.

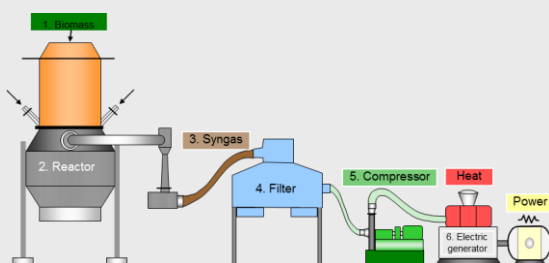

Incineration

In a “classic” incineration plant, the input material is burned in a boiler to create steam. This is used in a turbine to generate electricity. At the same time this technology can be used to dispose critical materials.



Your Partner



The **Novis** GmbH was founded in 2002 as a subsidiary of ILTIS GmbH to realize strategies and projects in the energy sector. **Novis** started built plants for energy production from all kinds of biological waste. Later this field was expanded to a wider range of input materials and technologies to find the most promising solution according to the special needs of each customer. To guarantee success in all of its international projects, **Novis** co-operates in a close network with various experts from Germany, who stand for technological leadership in their respective sectors. Over the last ten years **Novis** has realized numerous projects in Europe, Africa and Asia.

For more information contact **Novis** directly via phone, email or meet in person in the headquarters in Tuebingen, Germany.

Novis GmbH

Vor dem Kreuzberg 17
72070 Tuebingen
GERMANY

Tel: +49 7071 795 250 01
Fax: +49 7071 795 250 09
E-mail: dialog@novis.de
Internet: www.novis.com